

Optical Filters

Construction of Optical Filters

Turan Erdogan, PhD (CTO and Co-founder)

Semrock, A Unit of IDEX Corporation

May 31, 2011

Multiple interfaces lead to interference

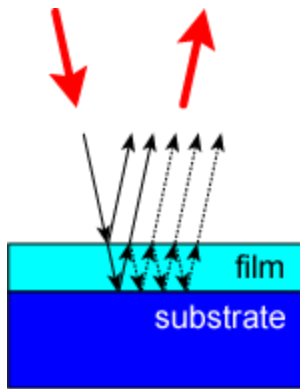

Multiple-path Interference

Properties of reflection and transmission are determined by the interference of many partially reflected light waves

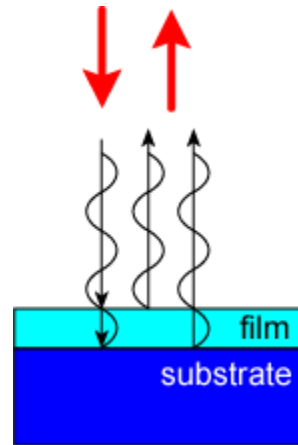

Constructive Interference

The waves reflected off of the successive interfaces add up in phase, thus yielding a large total reflection

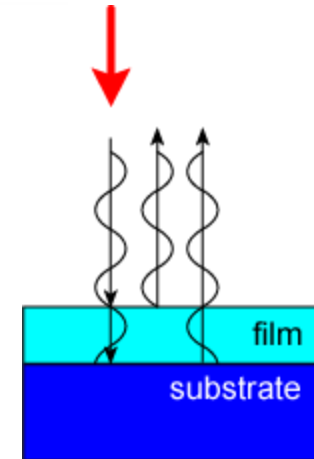

Destructive Interference

The waves reflected off of the successive interfaces add up out of phase, thus causing the light to be transmitted

Different wavelengths interfere differently

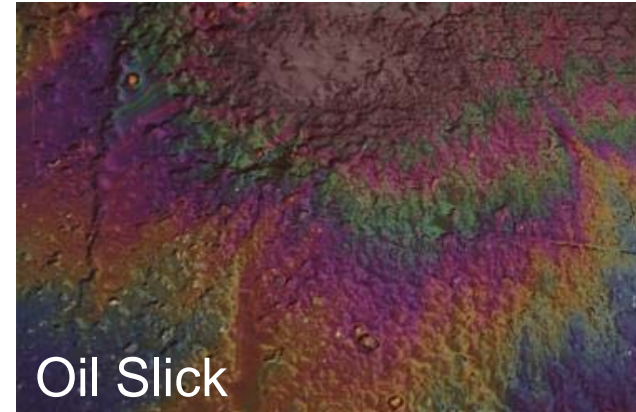
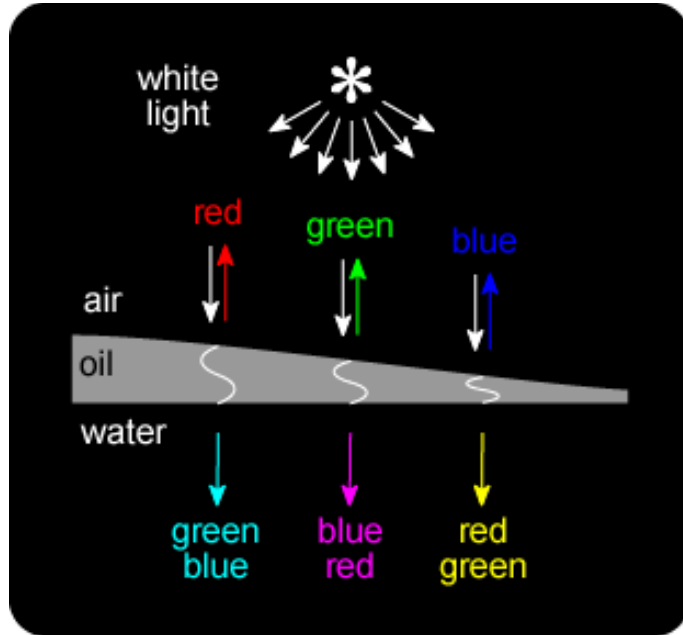

Interference leads to a wavelength dependence

For a given thickness, only light of the right wavelength interferes constructively. Leads to colorful thin-film effects, like rings on an oil slick or colors in a soap bubble.



Many “quarter-wave” layers → strong reflection

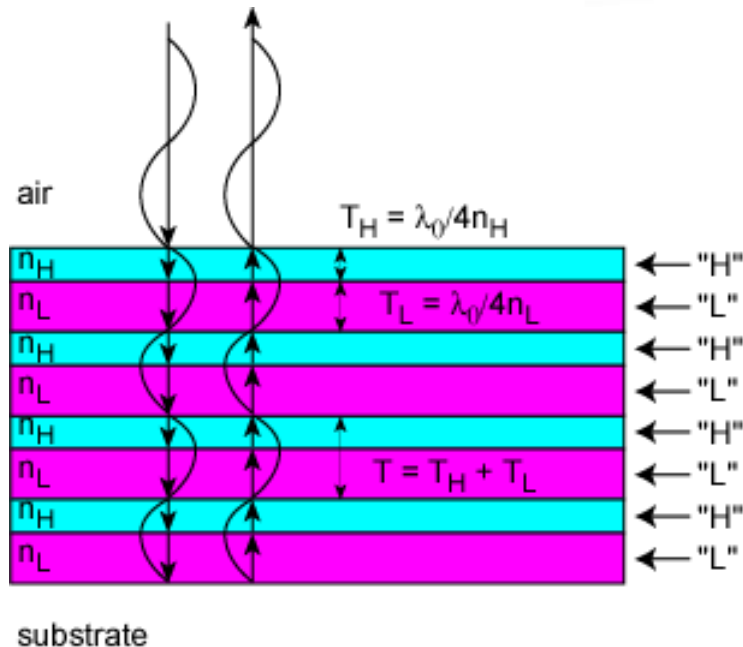

“Quarter-wave stack”

is a basic building block for thin-film filters; made up of alternating layers of high- and low-index material, each one quarter of an optical wavelength in thickness; light at the particular wavelength is strongly reflected.

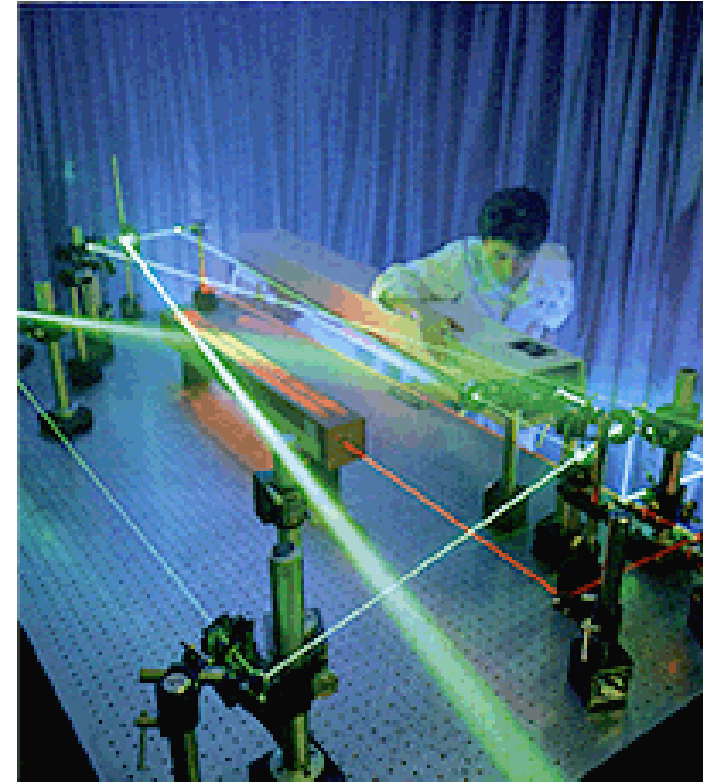

Dielectric laser mirrors are typically made with a quarter-wave stack

Spectrum from a “quarter-wave stack”

- As an increasing number of high (H) and low (L) index layers are added (in pairs), the transmission decreases (or reflection increases) over a region called the “**stopband**”

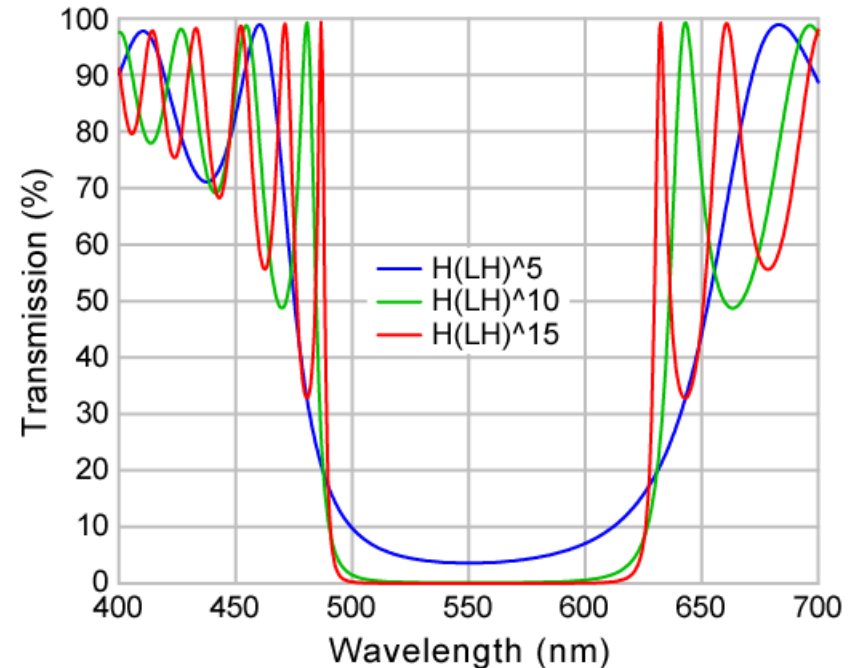
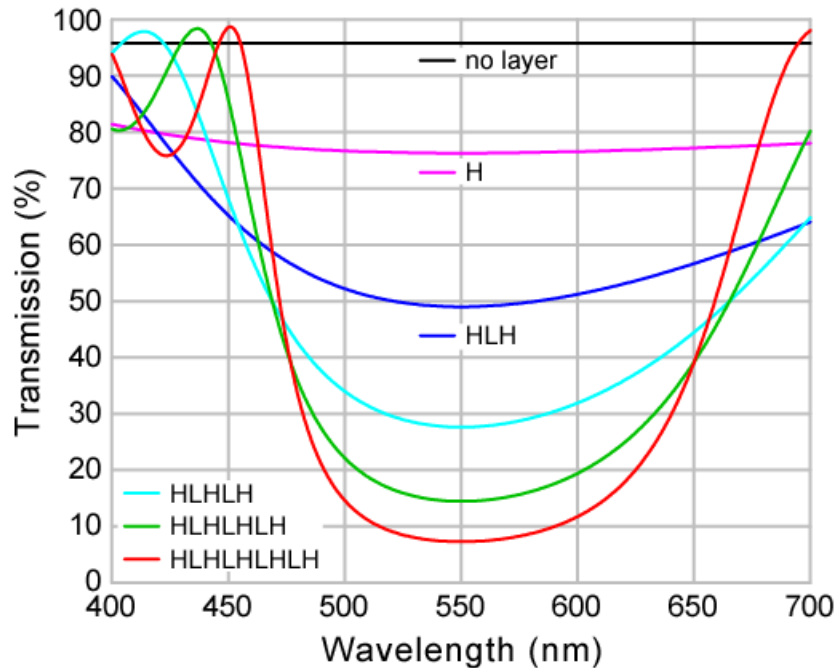

The layers are one quarter-wave thick at a wavelength $\lambda_0 = 550$ nm

$$n_H = 2.1 \quad n_{\text{air}} = 1.0$$

$$n_L = 1.46 \quad n_{\text{substrate}} = 1.52$$

Spectrum from a “quarter-wave stack”

- For many quarter-wave layers, large high-frequency “**ripple**” occurs in the transmitting regions outside the stopband
- At shorter wavelengths, “**harmonic stopbands**” show up – for a pure quarter-wave stack, only odd harmonics exist ($\lambda_0/3, \lambda_0/5, \dots$)

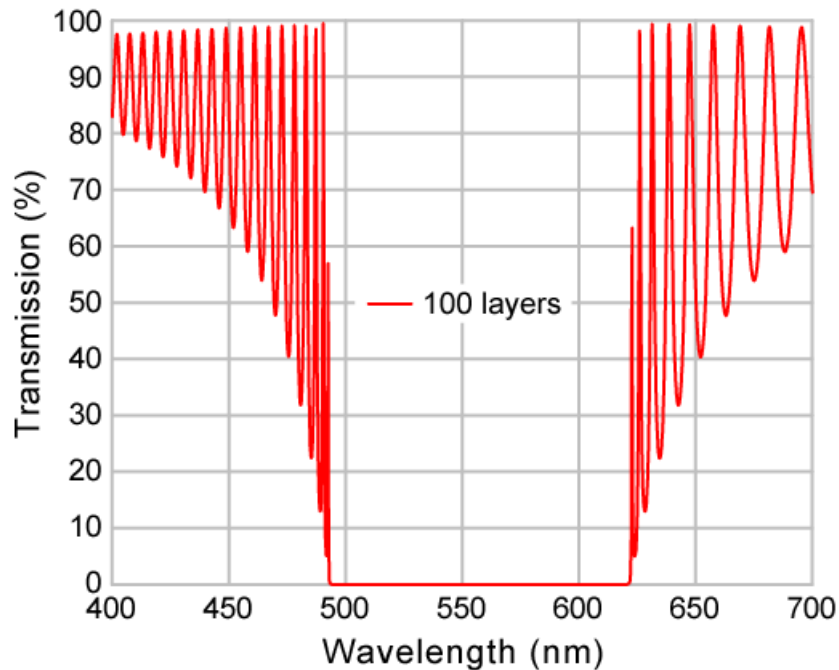

The layers are one quarter-wave thick at a wavelength $\lambda_0 = 550$ nm

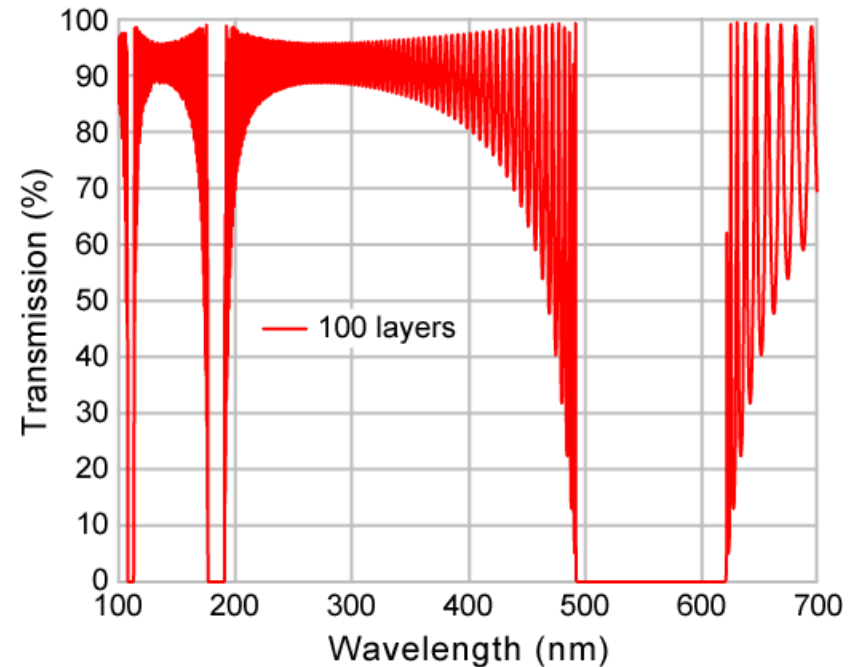

$$\begin{aligned} n_H &= 2.1 & n_{\text{air}} &= 1.0 \\ n_L &= 1.46 & n_{\text{substrate}} &= 1.52 \end{aligned}$$

Stopband harmonics

- It is important to understand where the stopband harmonics show up, because they can not always be eliminated completely, and they often get in the way of transmitting light where you want it to transmit
 - e.g., it is difficult to make a multi-photon emitter that both blocks light past 1000 nm (for a Ti:Sapphire laser) and transmits light at very short visible wavelengths (near 400 nm)

$$x = \frac{2}{\pi} \arcsin\left(\frac{n_H - n_L}{n_H + n_L}\right)$$

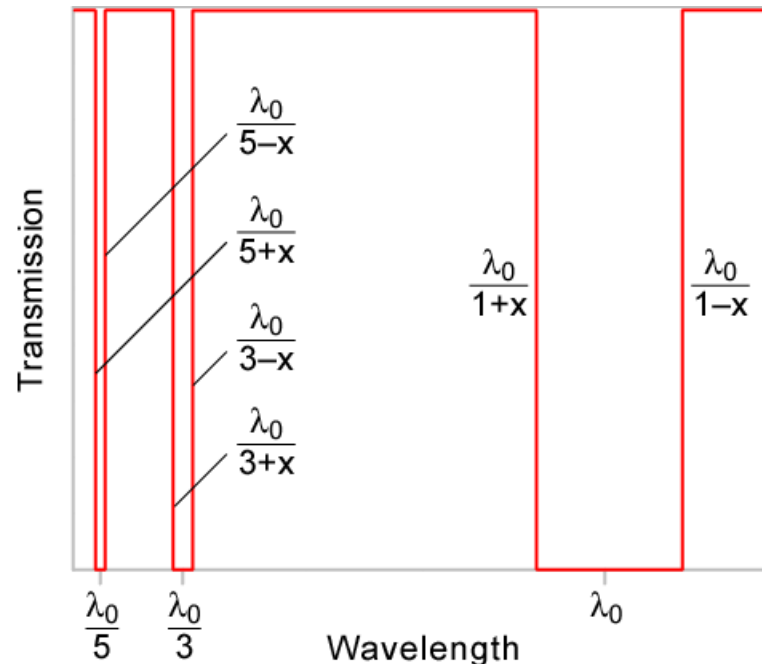

Edge filter

- By optimizing the layer structure using non-quarter-wave thick layers, the ripple outside the stopband can be greatly reduced on one side
 - Reduce ripple on the long-wavelength side for a **long-wave-pass (LWP)** edge filter (*example shown below*)
 - Reduce ripple on the short-wavelength side for a **short-wave-pass (SWP)** edge filter

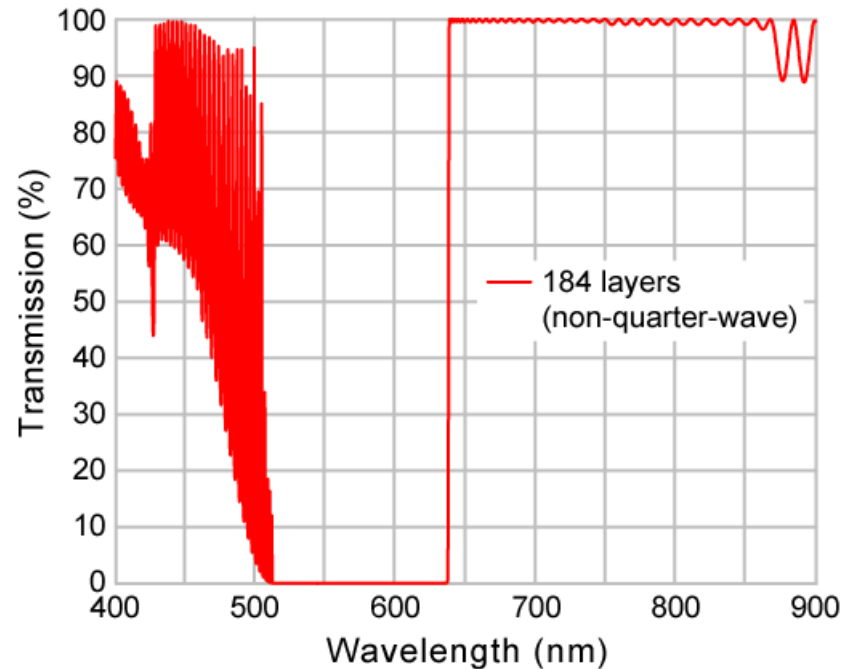

Edge filters for Raman spectroscopy

- The Raman “finger print” is measured by a spectrometer, but high-performance filters are needed to stop undesired source light from reaching the sample, and to prevent scattered laser light from overwhelming the measurement system

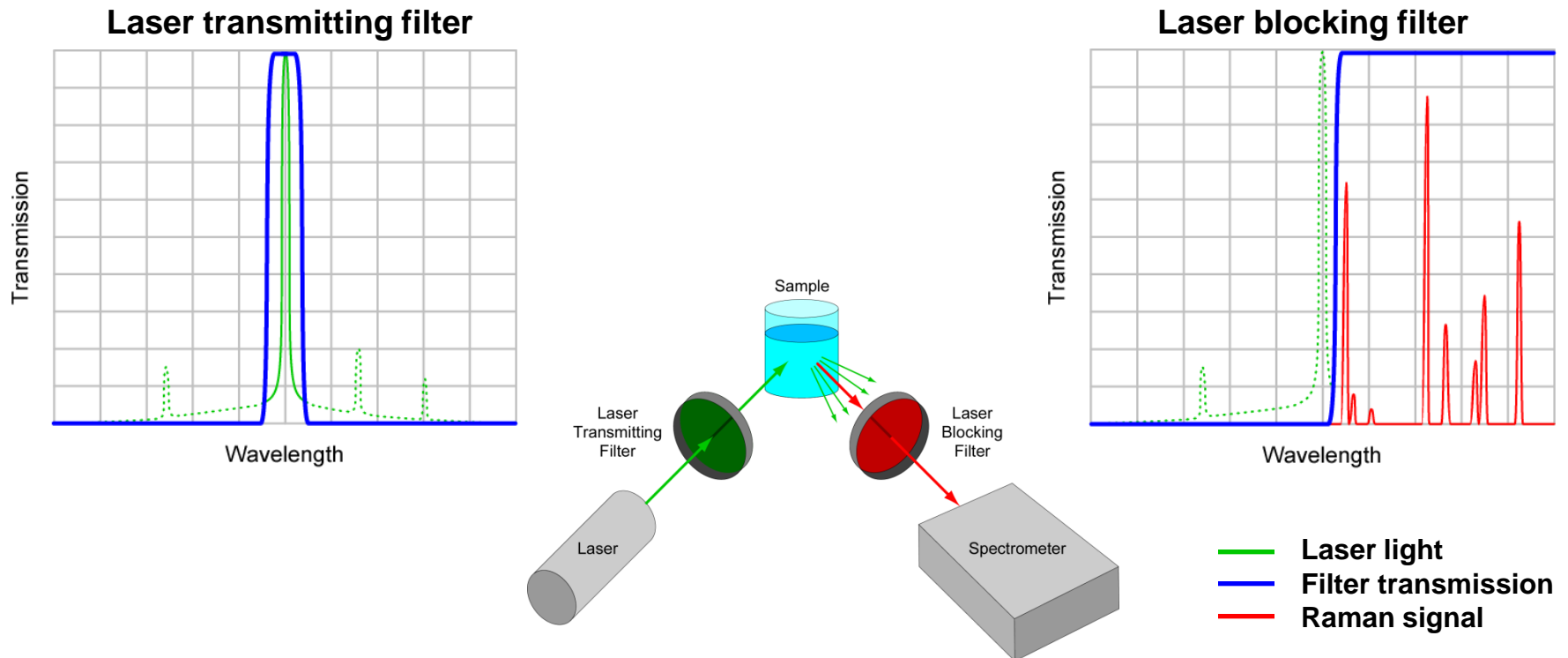

Long Wave Pass edge filter (RazorEdge[®])

- Typical spectra for 532 nm RazorEdge filter
- Note that that theoretical spectrum can be very accurately realized by the actual measured filter spectrum

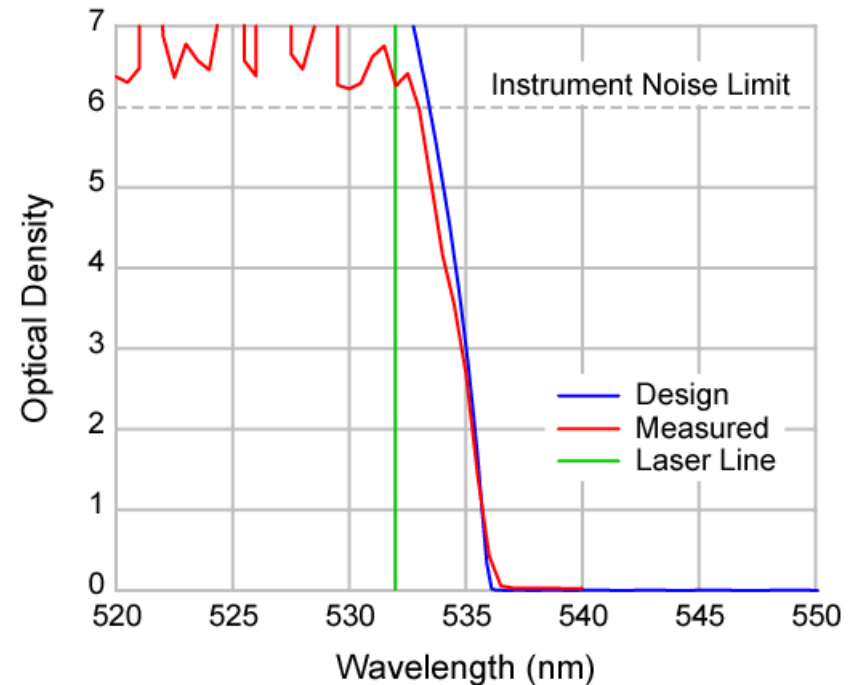
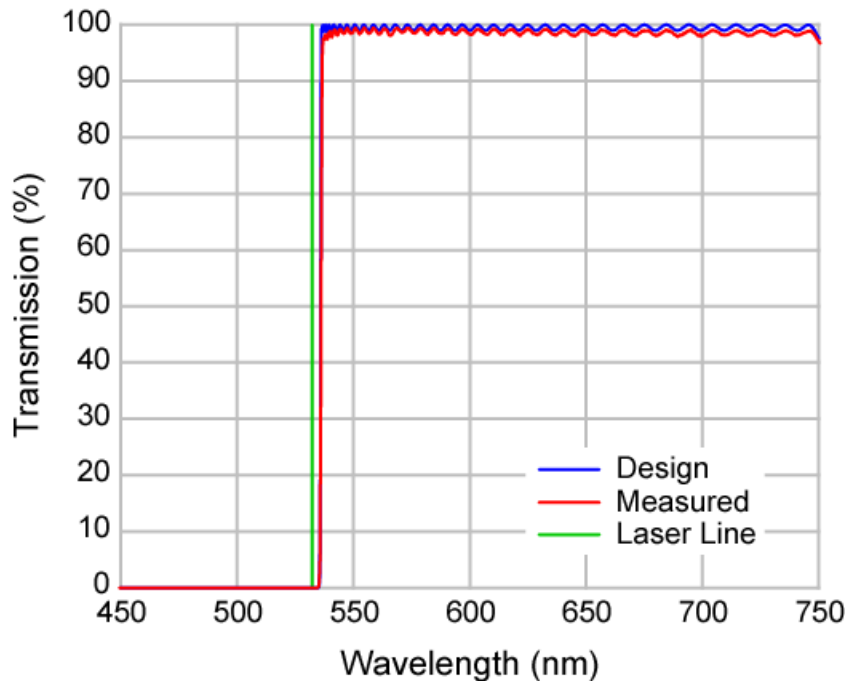

Notch filters (StopLine[®] U- and S-Grade)

- Stopbands (usually higher harmonics) are the basis for notch filters
- Notch filters effectively eliminate a narrow band of wavelengths (e.g., a laser line) while transmitting all other wavelengths as much as possible

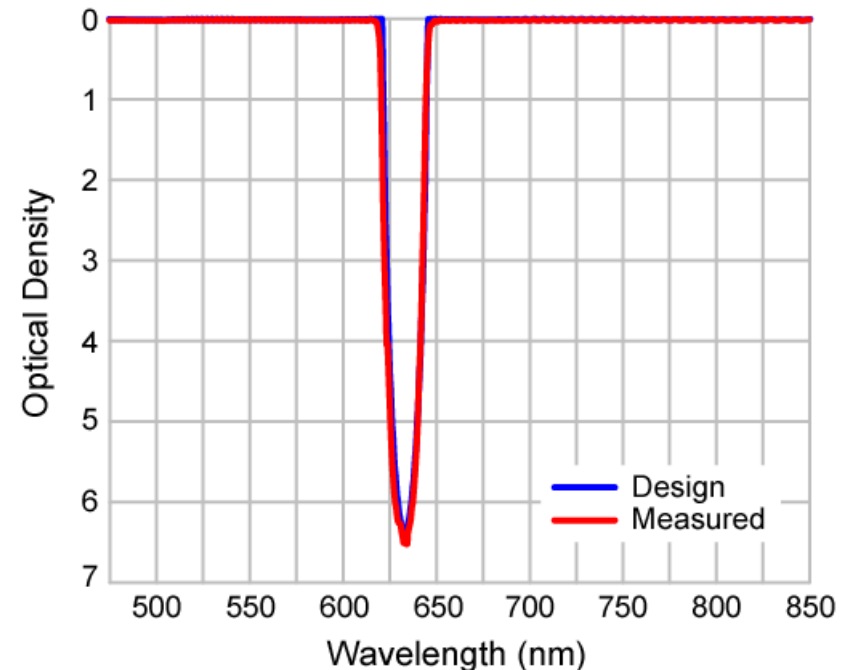
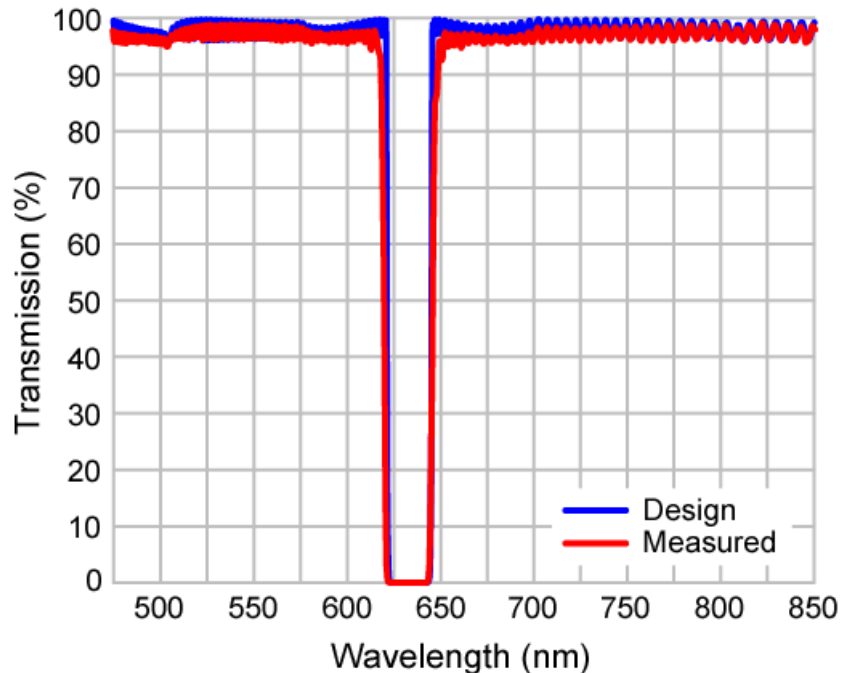

- Deep notch (OD > 6)
- Narrow bandwidth (< 4% of the laser wavelength)
- High transmission outside the notch (> 95%)

Multi-notch filters (StopLine[®])

- Filters can also be made with low ripple around more than one notch
- Complex, non-quarter-wave thick layers are required to make these sophisticated filters with notches that occur at non-harmonically related wavelengths

405 / 488 / 561-568 nm Triple-notch Filter

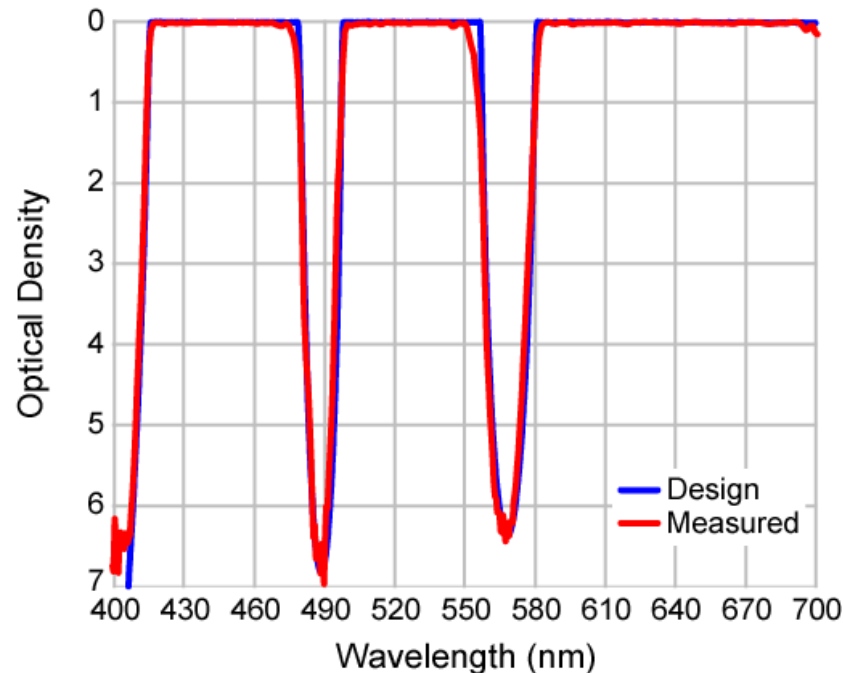

New StopLine® “E-Grade” notch filters

- Semrock’s new StopLine® E-Grade notch filters utilized a brand new design approach that offers an ultra-wide passband region that extends from < 350 nm to > 1600 nm!

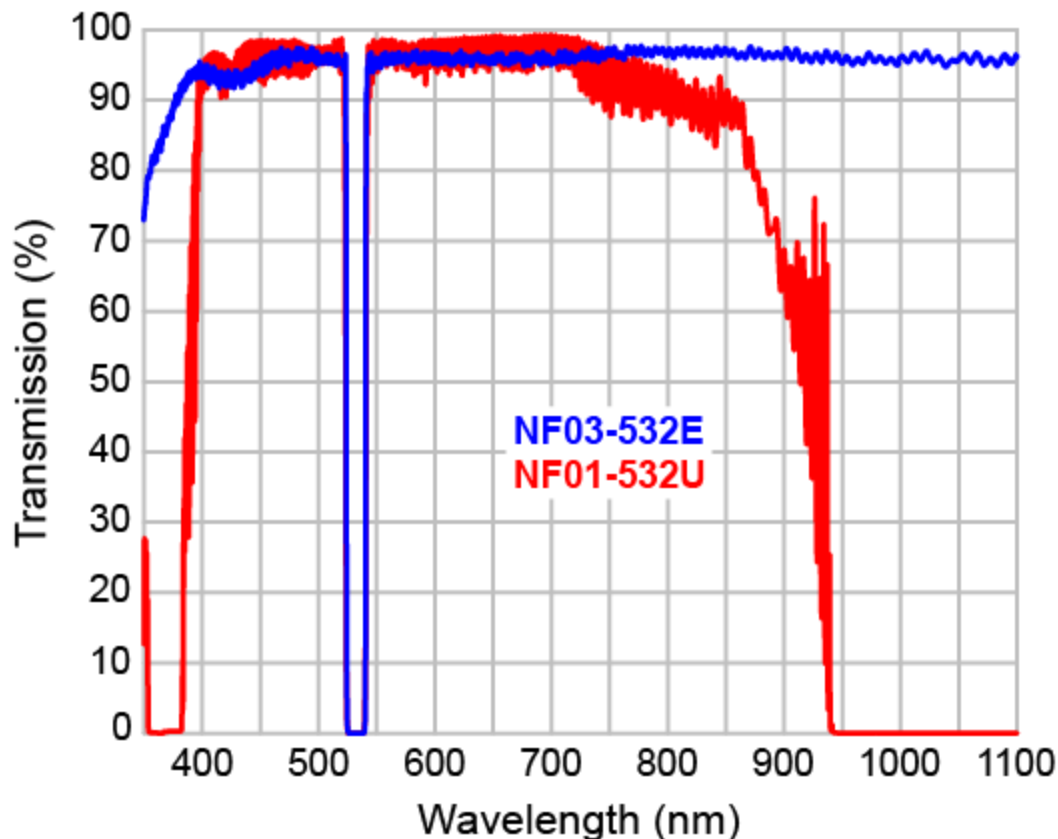

Typical measured data for the 532nm filter is shown.

“Fabry-Perot” (narrow bandpass) filter

- Two quarter-wave stacks combined with a “spacer” layer between them (an integer number of half wavelengths thick) form what is called a **“Fabry-Perot cavity”**
- At the center of the stopband λ_0 , the light constructively interferes in transmission over a very narrow bandwidth

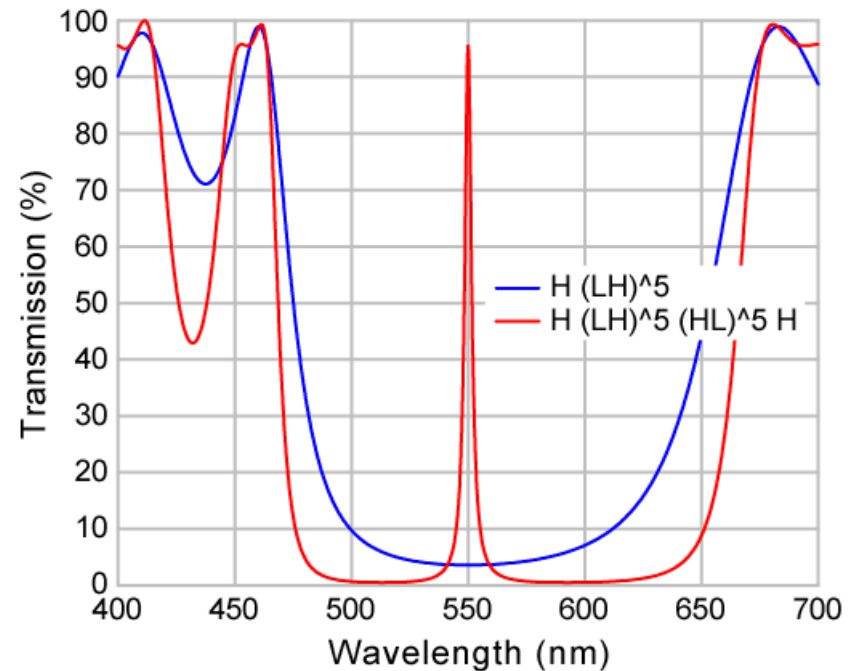
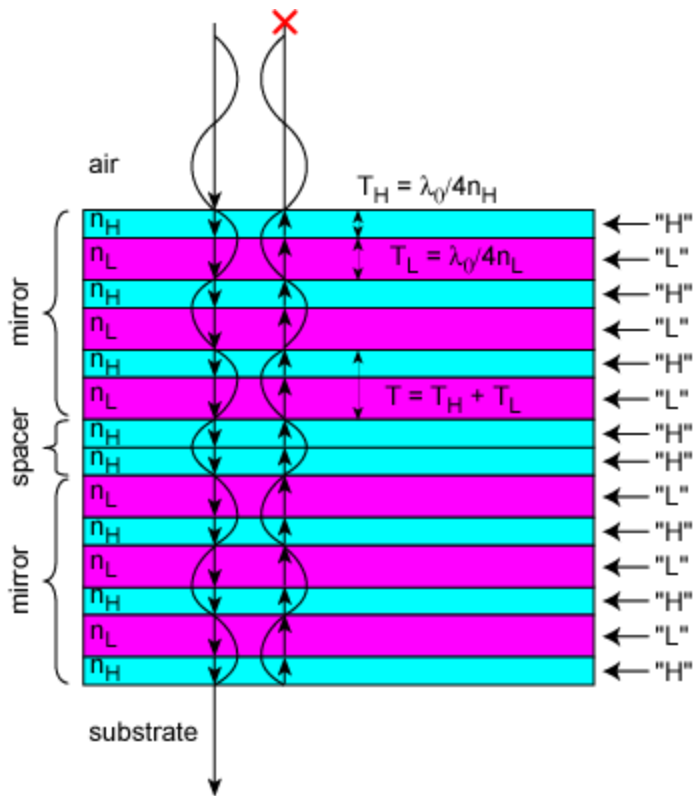

Multi-cavity Fabry-Perot filter

- Increasing the number of cavities increases the steepness of the passband edges and flattens the top of the passband while the bandwidth remains constant
- By adding more quarter-wave layers at the appropriate places, the top of the passband can be made even more flat (not shown here)

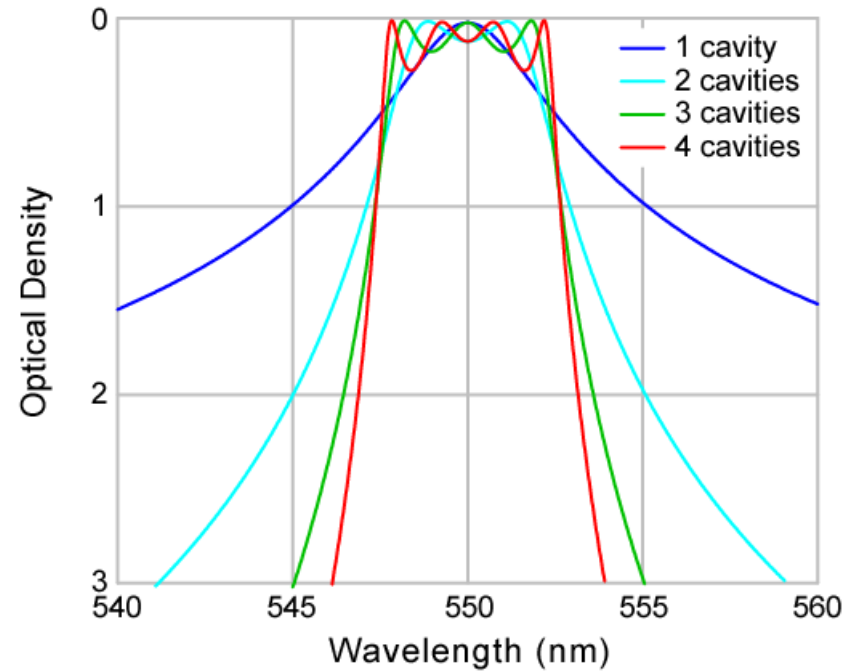
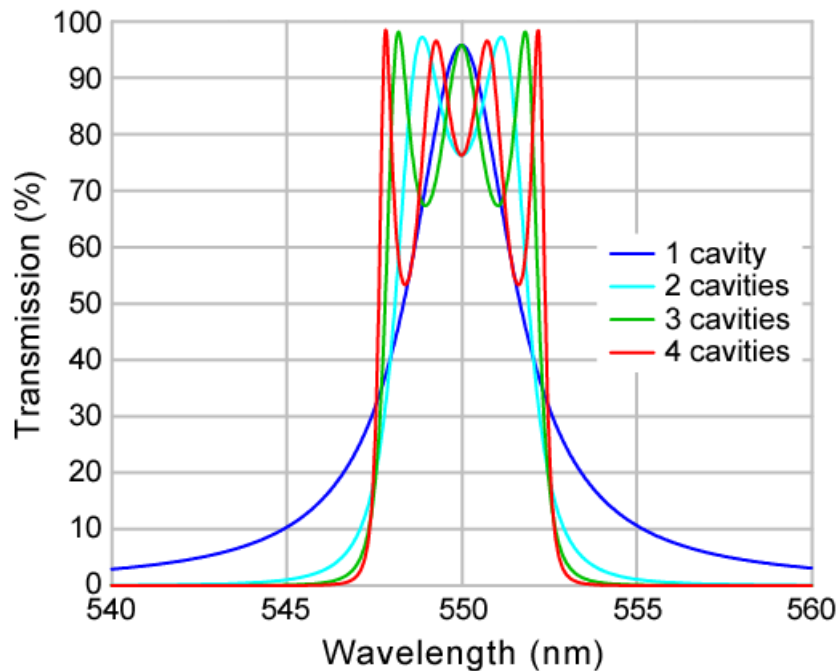

Multi-cavity Fabry-Perot filter example (MaxLine®)

- This 488 nm filter also has “extended blocking” at wavelengths outside of the stopband to ensure that all unwanted laser noise is eliminated

< 2 nm wide, yet > 90% transmission

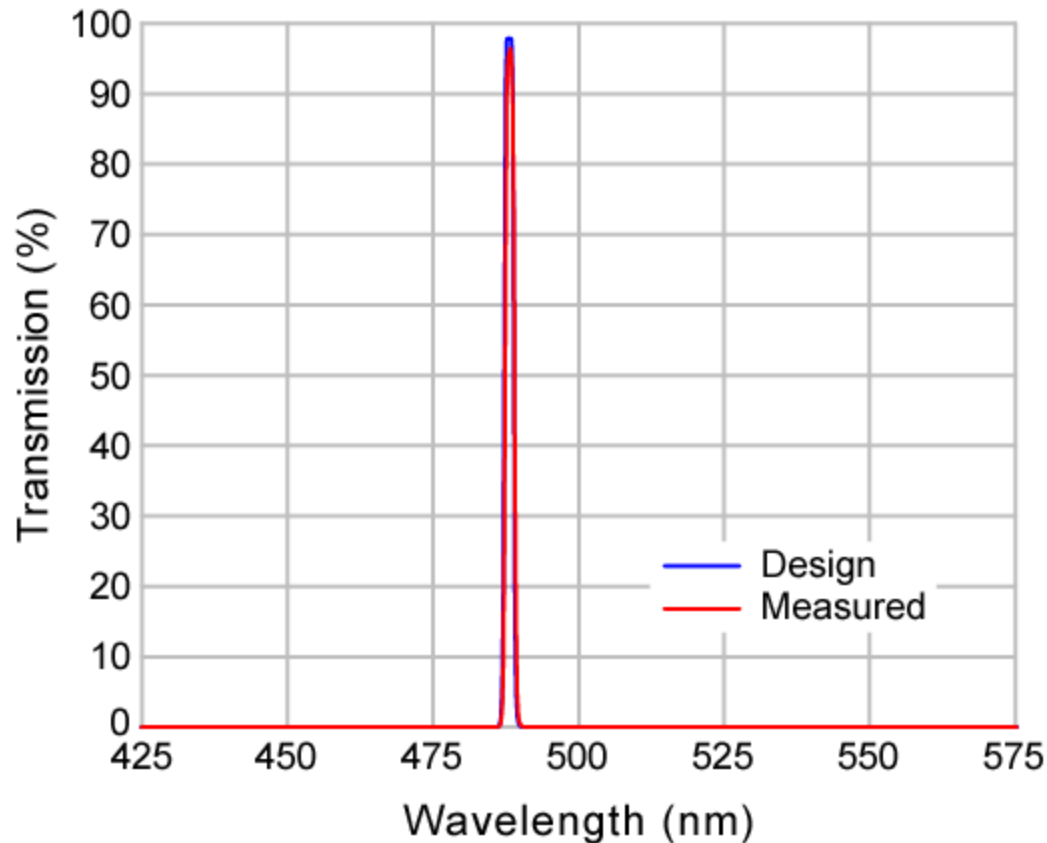

Diode laser “clean-up filter” (MaxDiode™)

- Diode laser wavelengths vary from laser-to-laser, with temperature, and with the lifetime of the laser – this multi-cavity Fabry-Perot filter with many cavities achieves very high transmission over a very flat (low-ripple) passband region

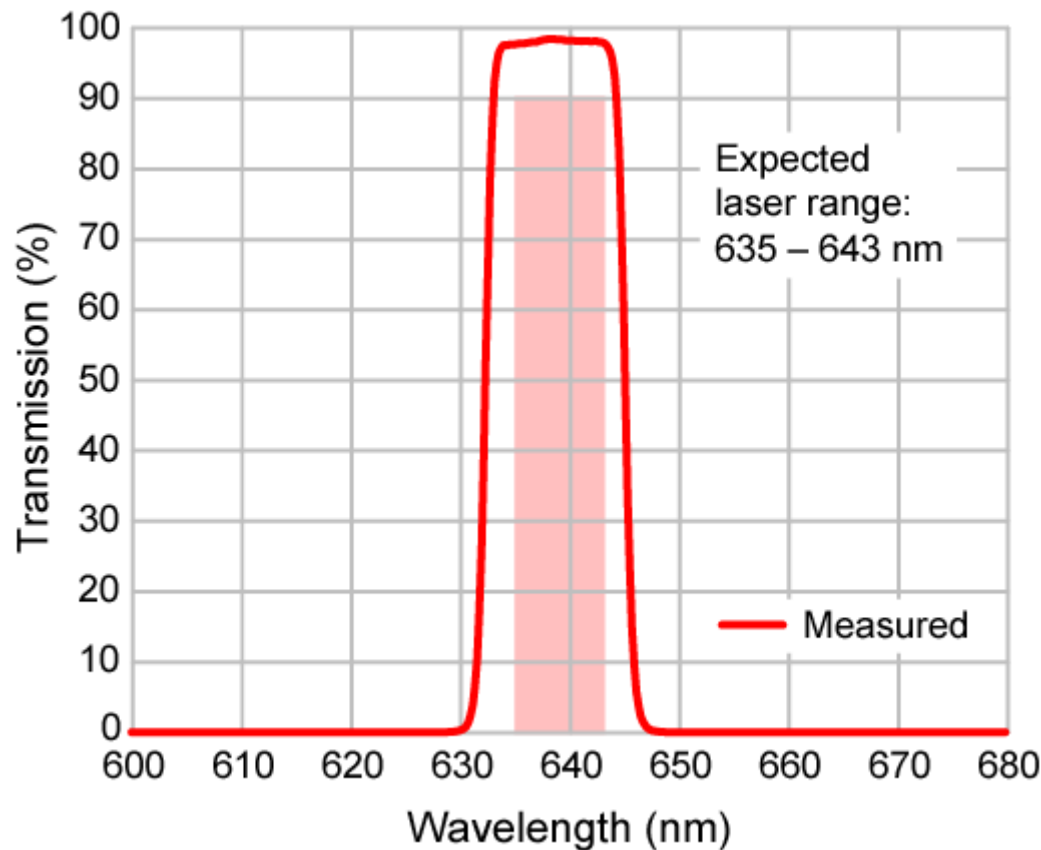

Bandpass filter by combining LWP-SWP

- For **incoherent light**, the combination of two edge filters – an LWP (long-wave-pass) and an SWP (short-wave-pass) – “looks like” a single-coating bandpass filter*

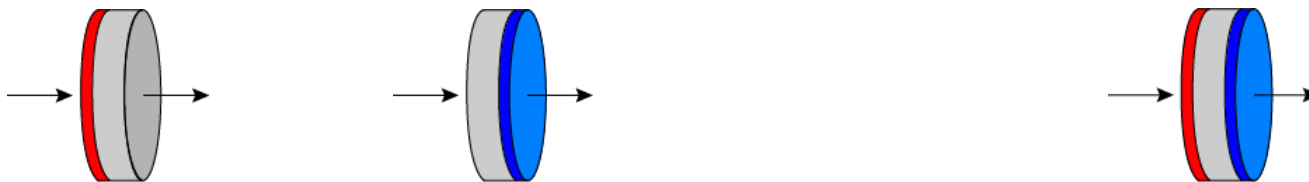
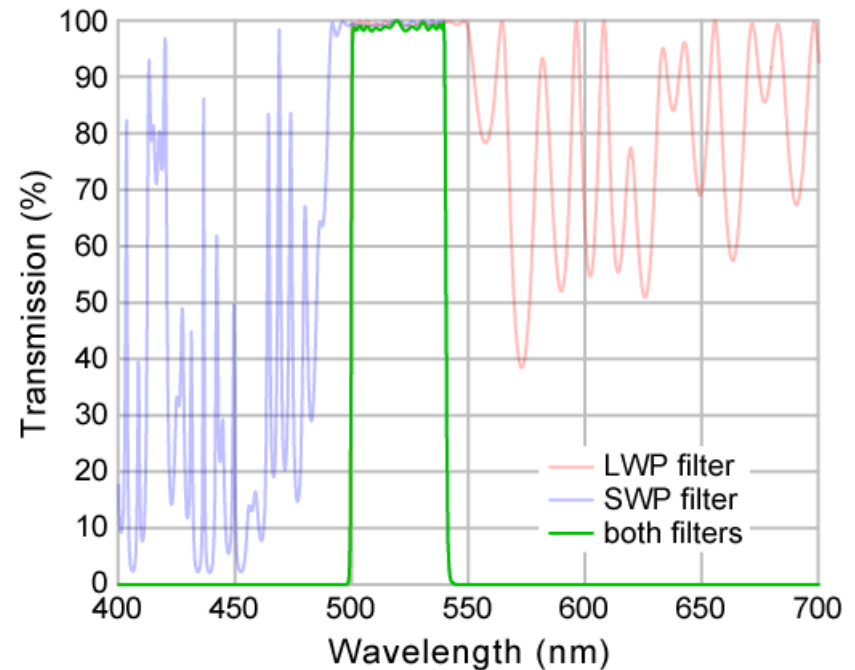
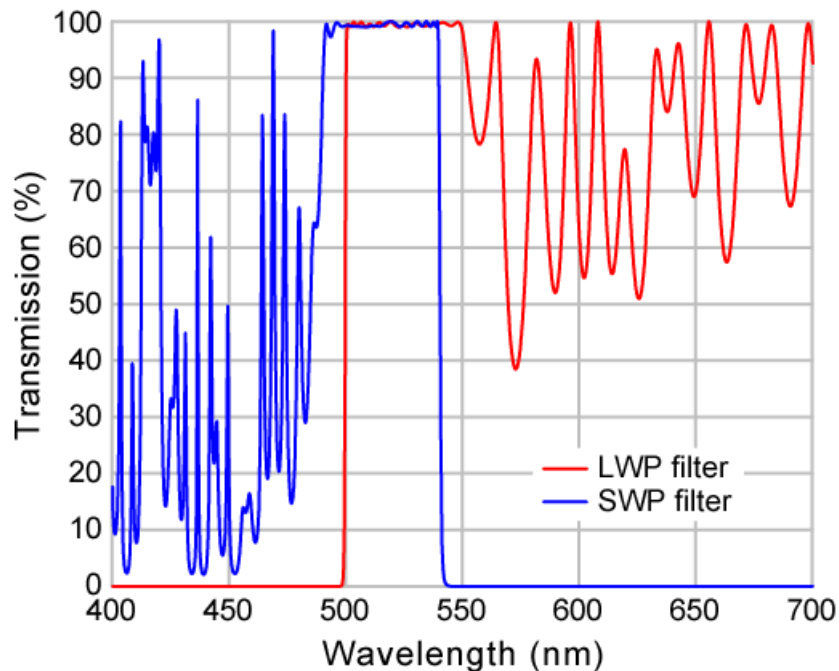

Bandpass Fluorescence Filters (BrightLine[®])

- Example GFP-3035B filter set overlaid on GFP spectra

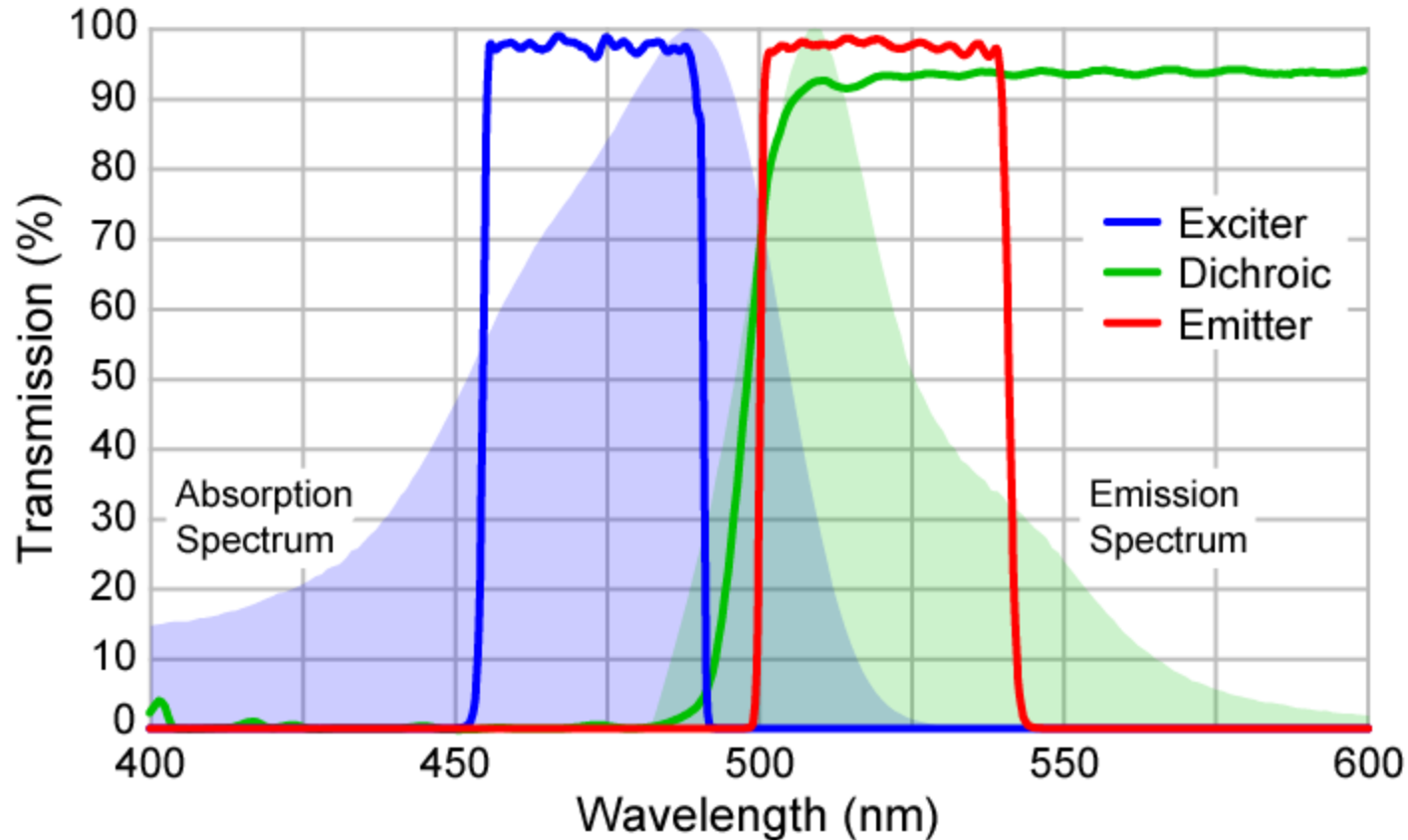

Thin-film filter manufacturing – monitoring

- Precise narrowband filters are made from **quarter-wave** layers using “**turning-point**” optical monitoring

- Quarter-Wave of High-Index Material
- Quarter-Wave of Low-Index Material
- Substrate Material

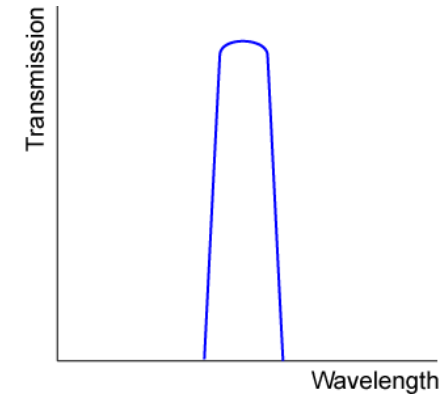
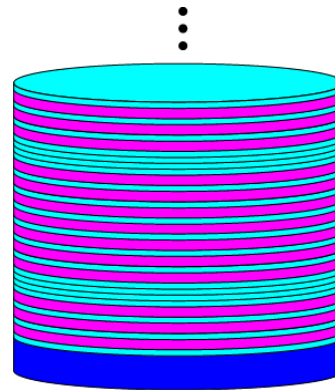

Switch materials at well-defined points on the curve of transmission vs. time

Self-correcting process!

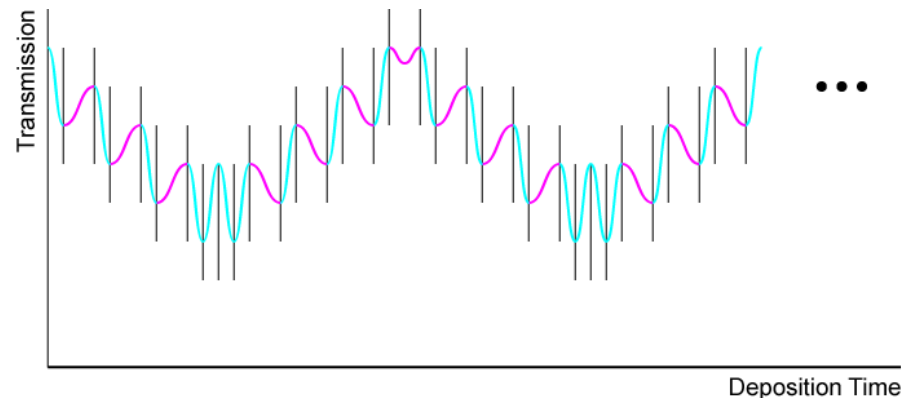

Thin-film filter manufacturing – monitoring

- **Non quarter waves** offer exceptional flexibility for more difficult spectral profiles, but optical monitoring is also more difficult

- High-Index Material - Not Quarter Wave!
- Low-Index Material - Not Quarter Wave!
- Substrate Material

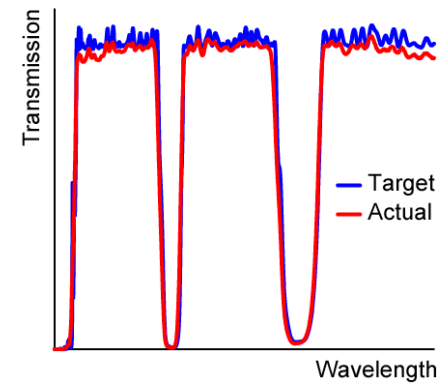
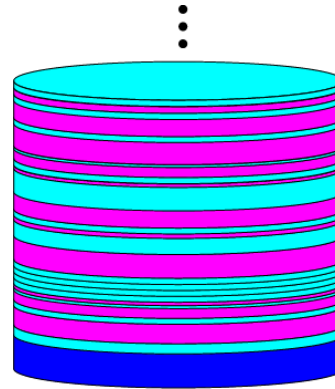

Successful optical monitoring demands more sophisticated algorithms to achieve high total filter thickness

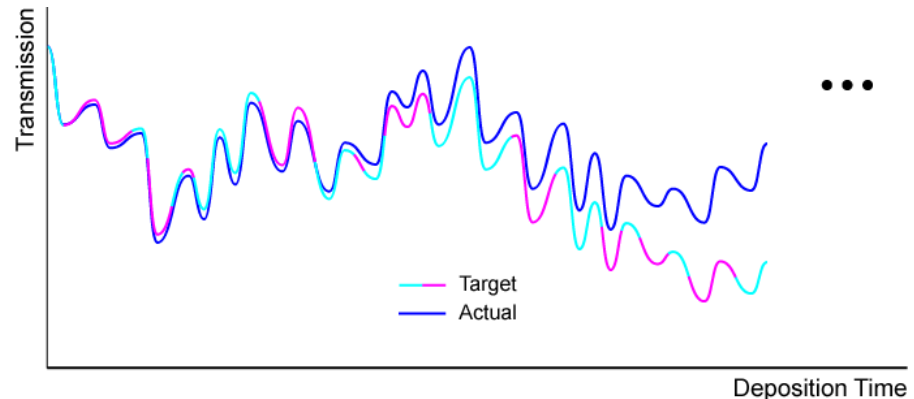

Thin-film filter manufacturing – deposition

- Two main approaches for manufacturing optical thin-film filters for high-performance fluorescence instrumentation and microscopes today:
 - Thermal / electron-beam evaporation
 - Traditional approach; has been around for decades
 - Ion-assisted Ion-Beam Sputtering (IBS)
 - The **new technology**; adapted from recent developments in thin-film technology engineered for telecom applications

Deposition by evaporation (electron beam)

- “Traditional approach” – special form of thermal evaporation
- Thickness/number of layers limited to about 10 – 20 layers (w/ no optical monitoring), or 10’s (< 100) of layers (w/ optical monitoring)
- Therefore large index contrast needed just to achieve steep filter edges
- As a result, most common materials used are Zinc Sulfide (ZnS ; $n = 2.35$) and Sodium Aluminum Fluoride (“cryolite” or Na_3AlF_6 ; $n = 1.35$)
 - *These are “soft” coating materials*
- Other aspects of filter spectra are still limited by insufficient layers (like steep edge for a 45° dichroic beamsplitter)

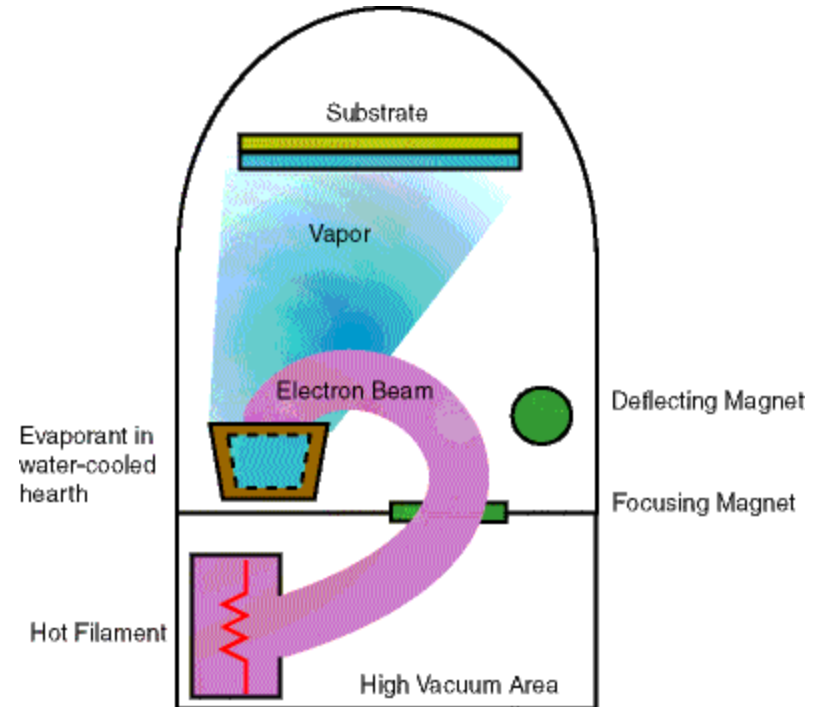

Ion-assisted ion-beam sputtering (IBS)

- Originally developed for coating precise ferrite thin films on magnetic disk drives and extremely low-loss mirrors for ring-laser gyro applications
- Then adapted for extremely high-performance optical filters for Telecom/WDM in the late 1990's
- Based on hard refractory oxide materials like silica (SiO_2 ; $n = 1.45$), tantala (Ta_2O_5 ; $n = 2.1$), and niobia (Nb_2O_5 ; $n = 2.3$) – as hard as the glass substrates on which they are coated
- Demonstrated ability to coat many 100's of layers with extremely high precision

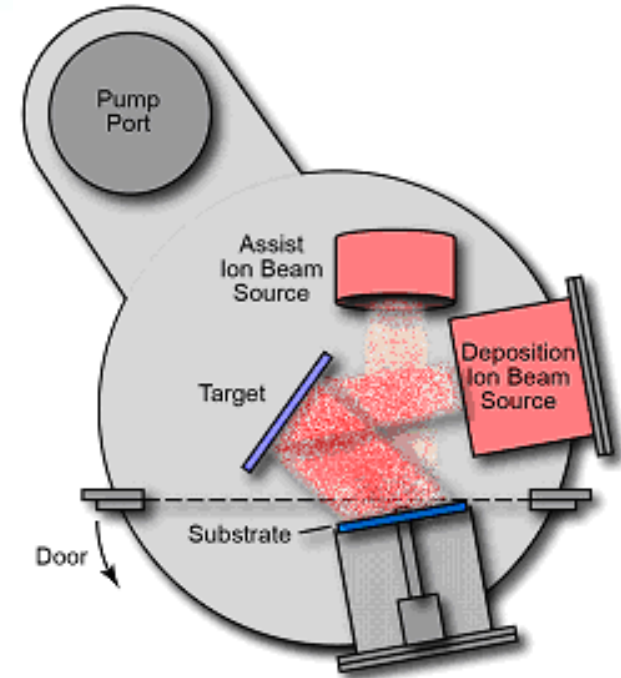

Comparison of coating approaches

	Electron-beam / Thermal Evaporation	Ion-assisted Ion-beam Sputtering
Deposition Process	Physical Vapor Deposition	Energetic Physical Vapor Deposition
	Variable deposition rates	Extremely stable deposition rates
	Variable spatial uniformity	Controllable spatial uniformity
Resulting Thin Films	Soft coatings	Hard, dense coatings
	Low durability	Very high durability
	Hygroscopic (absorb moisture)	Impervious to humidity
	Appreciable temperature shifting	Very low temperature shifting
	Some scattering	Very low scattering
	Some absorption	Very low absorption
	Low film stress	Reproducible film stress

Comparison of coating approaches

- Differences in film density are readily apparent (AFM data)

**E-beam Evaporated
Soft Coating**

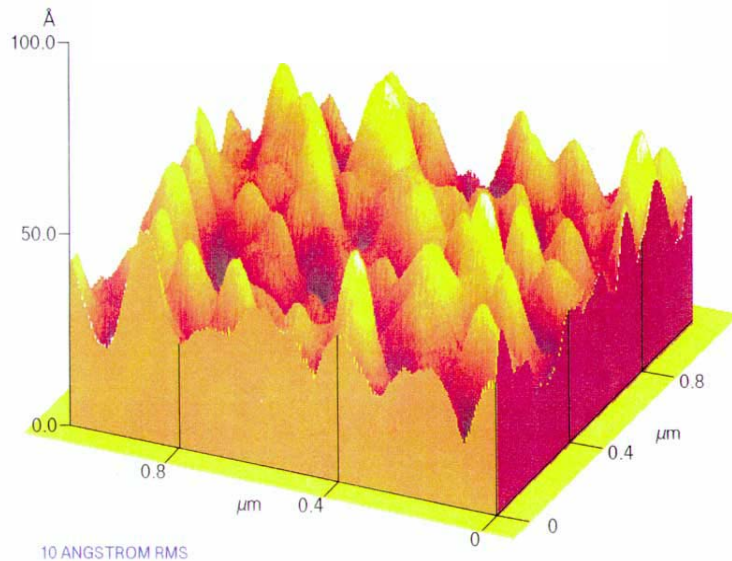

**Ion-Beam Sputtered
Hard Coating**

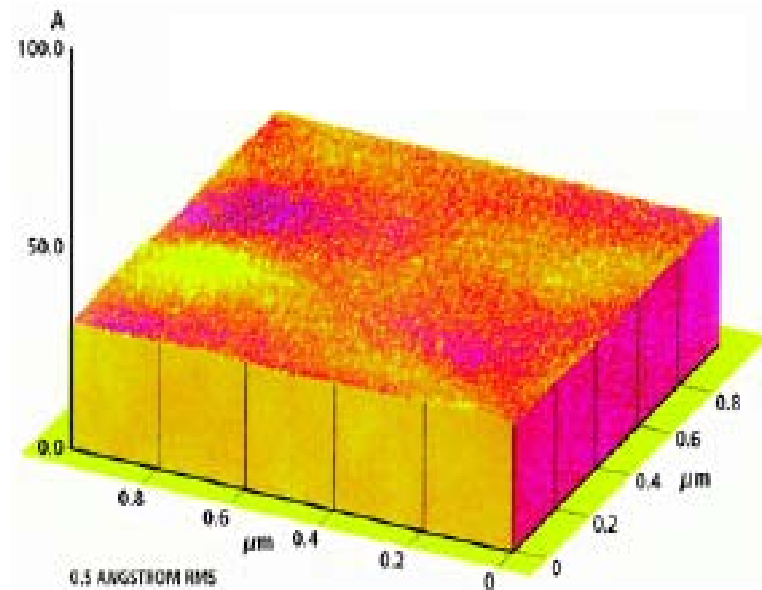

Data from: *Optical Morphology: Just How Smooth Is That Surface?* Photonics Spectra, June 1998

IBS advantage – very repeatable process

- The inherent stability of the IBS process enables an incredibly high degree of batch-to-batch reproducibility

- **Microscope exciter filter**
- **4 different batches**
- **Different machines / different times**

- **Small-animal-imaging emitter filter**
- **20 different batches**
- **Different machines / different times**

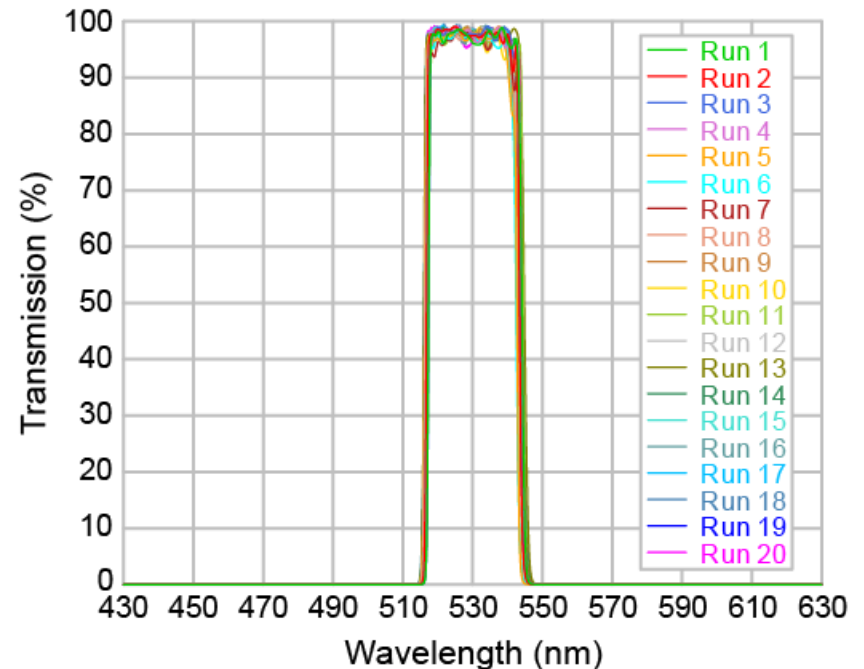
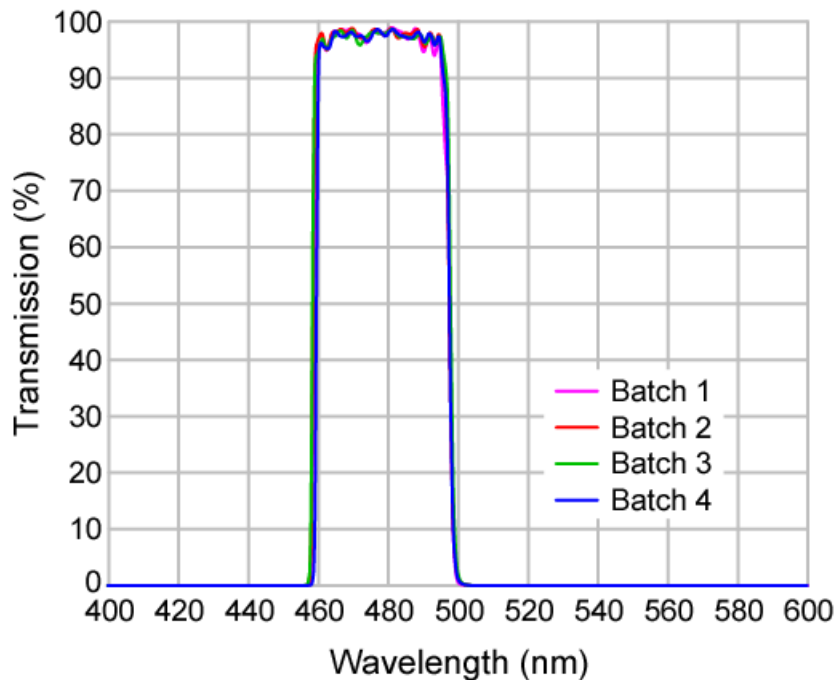

IBS advantage – durability and longevity

- Proven reliability even in harsh (e.g., aqueous/solvent) environments
- **Will not “burn out”** under prolonged, intense optical irradiation from bright fluorescence lamps or lasers (high “laser damage threshold”)
- All filters (even dichroics) can be handled/cleaned like any glass optics

Environmental Durability Test	Standard / Procedure	Test Description
Humidity	MIL-STD-810F (507.4)	Aggravated Humidity (> 10 x 24 hr cycles)
High Temperature	MIL-STD-810F (501.4)	Induced Hot (> 7 x 24 hr cycles)
Low Temperature	MIL-STD-810F (502.4)	Cold (C2) (24 hr cycles)
Physical Durability Test	Standard / Procedure	Test Description
Adhesion	MIL-C-48497A (4.5.3.1)	“Tape Test”
Humidity	MIL-C-48497A (4.5.3.2)	Damp Heat
Moderate Abrasion	MIL-C-48497A (4.5.3.3)	“Cheesecloth Test”
Solubility/Cleanability	MIL-C-48497A (4.5.4.2)	Acetone and Alcohol Immersion
Water Solubility	MIL-C-48497A (4.5.5.3)	Distilled Water Immersion



Environmental test lab

IBS advantage – durability and longevity

- Filter spectra measured before & after an aggressive **10** 24-hour cycles of Aggravated Humidity testing according to MIL-STD-810F

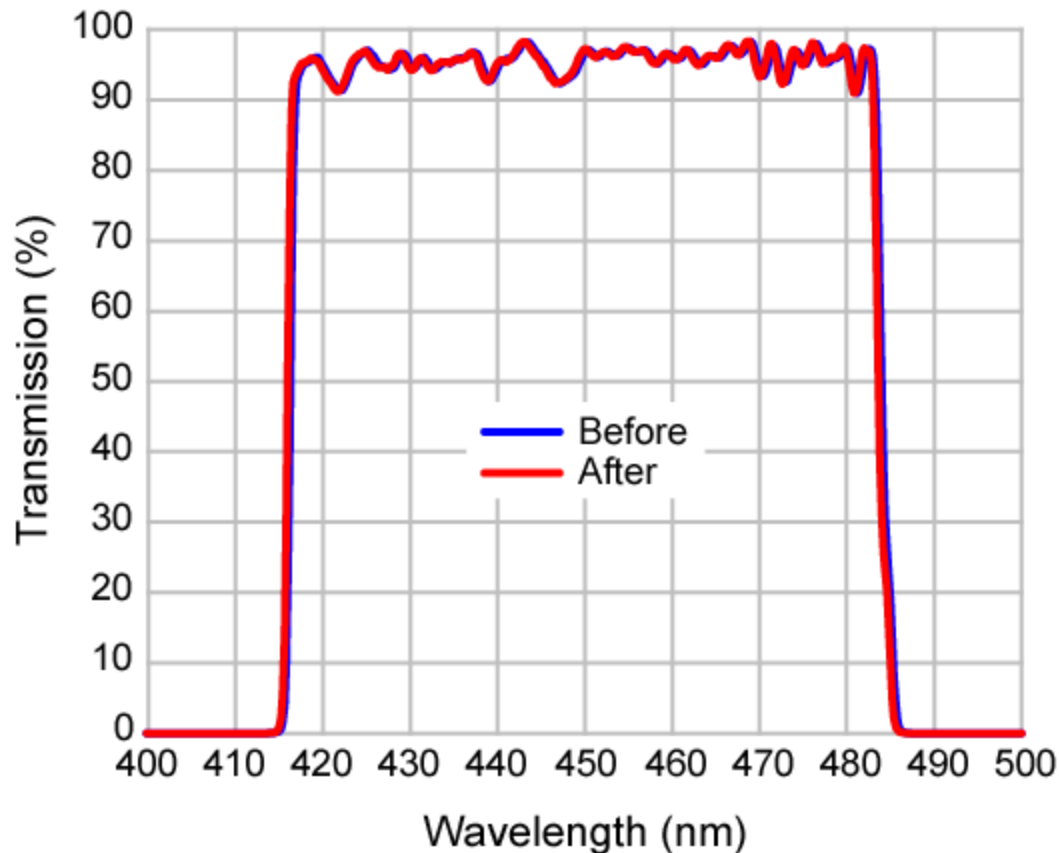

Simpler construction (e.g., BrightLine[®] filters)

- **Semrock's durable coatings are as hard as the glass substrate, permitting a simple one-piece filter construction***

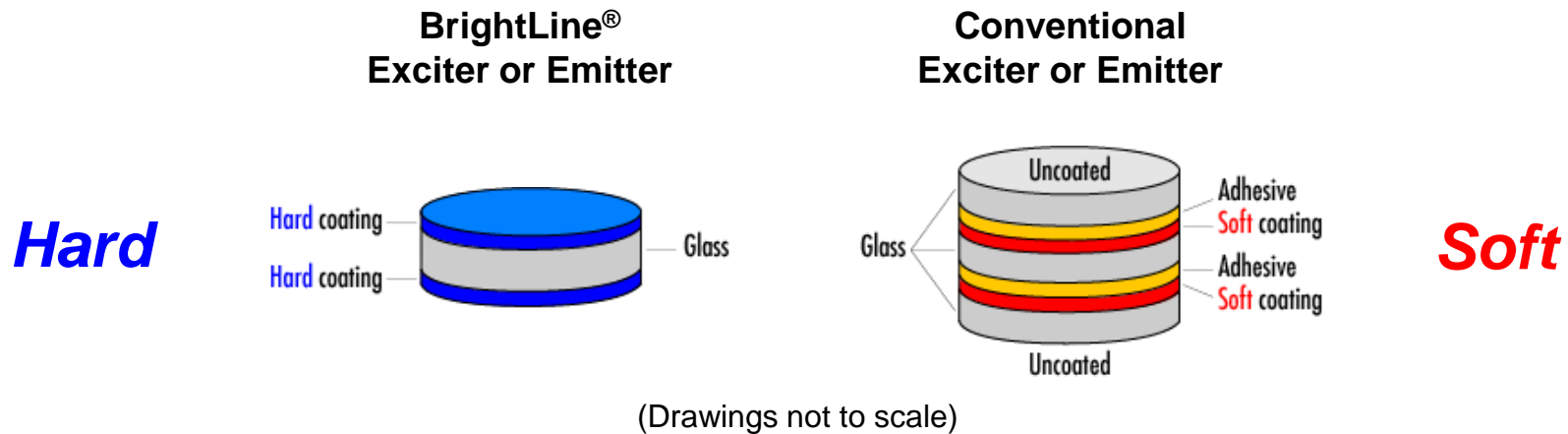

- Fewer interfaces to reflect or scatter light → **highest throughput**
- No adhesive to optically damage, degrade or autofluoresce → **most reliable**
- All optical surfaces may even be cleaned with acetone → **very durable**

** US Patent 6,809,859 and pending*

Optical durability – Semrock filters don't “burn out”!

- Two filters exposed to 15 Watts from a Xe arc lamp over central 15 mm for first 24 hours; then to 2.5 W (reproduces back port of a fluorescence microscope)

Competitor Premium DAPI Exciter
After < 300 hrs



Semrock DAPI Exciter
After > 1000 hrs



Optical durability – Semrock filters don't “burn out”!

- Two filters exposed to 6 Watts of power from a Xenon arc lamp (with diameter to reproduce back port of a fluorescence microscope) for 5 days

**Competitor premium
soft-coated GFP exciter filter**

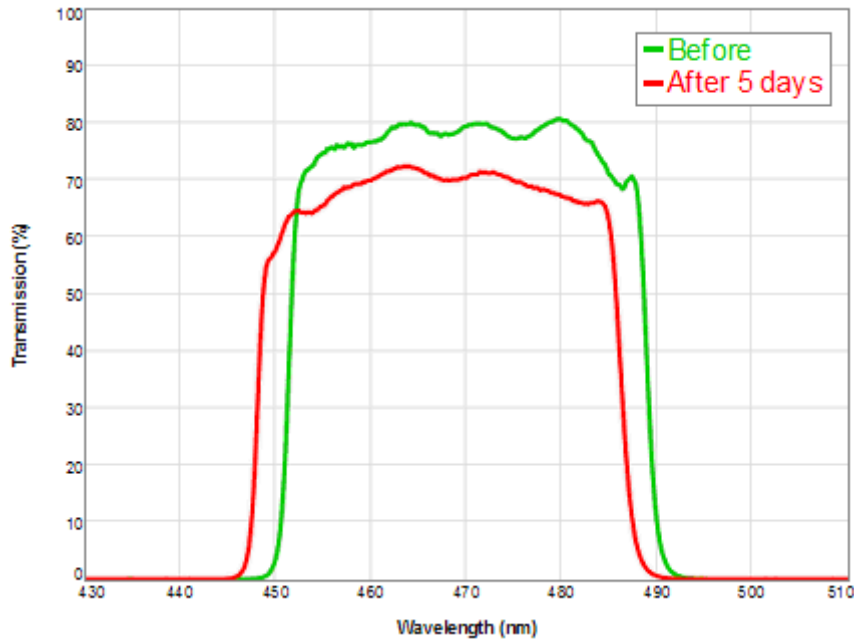

**Semrock BrightLine®
hard-coated FITC exciter filter**

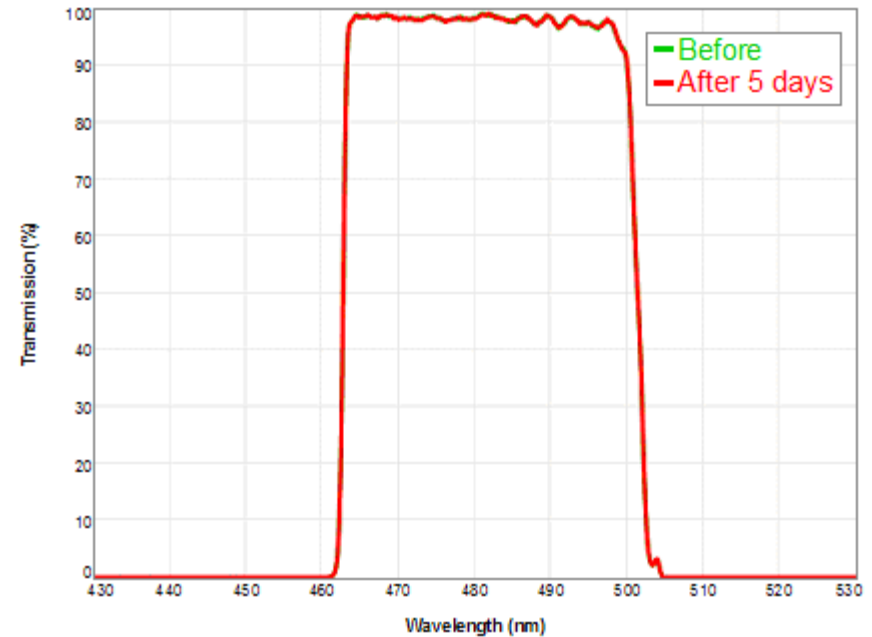

Optical durability – Semrock filters don't “burn out”!

- Different filters exposed to 6 Watts of power from a Xenon arc lamp (with diameter to reproduce back port of a fluorescence microscope) for 5 days

Change in Transmission
Soft-coated filters degrade!

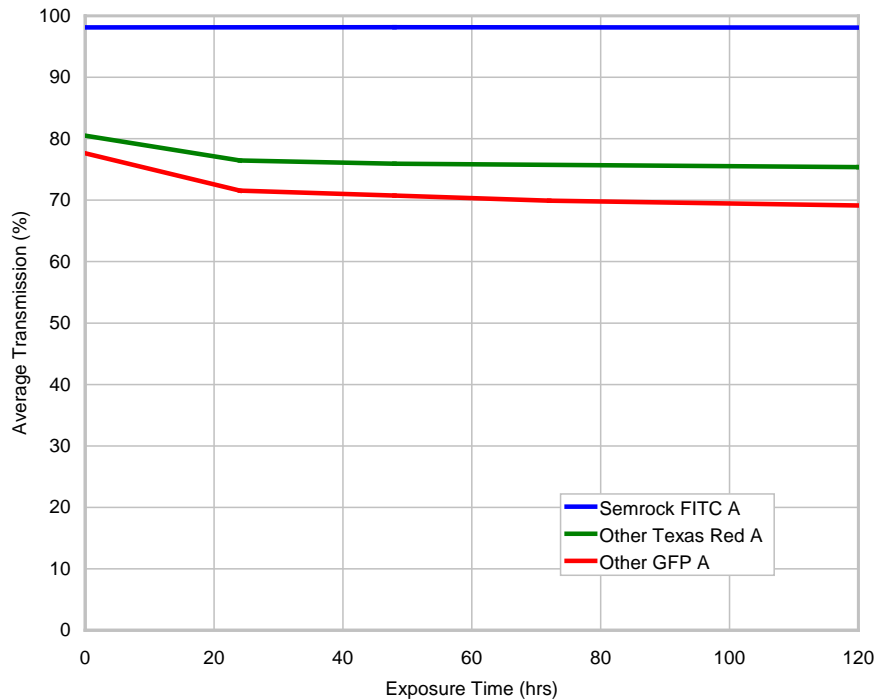

Change in Edge Position
Soft-coated filters shift!

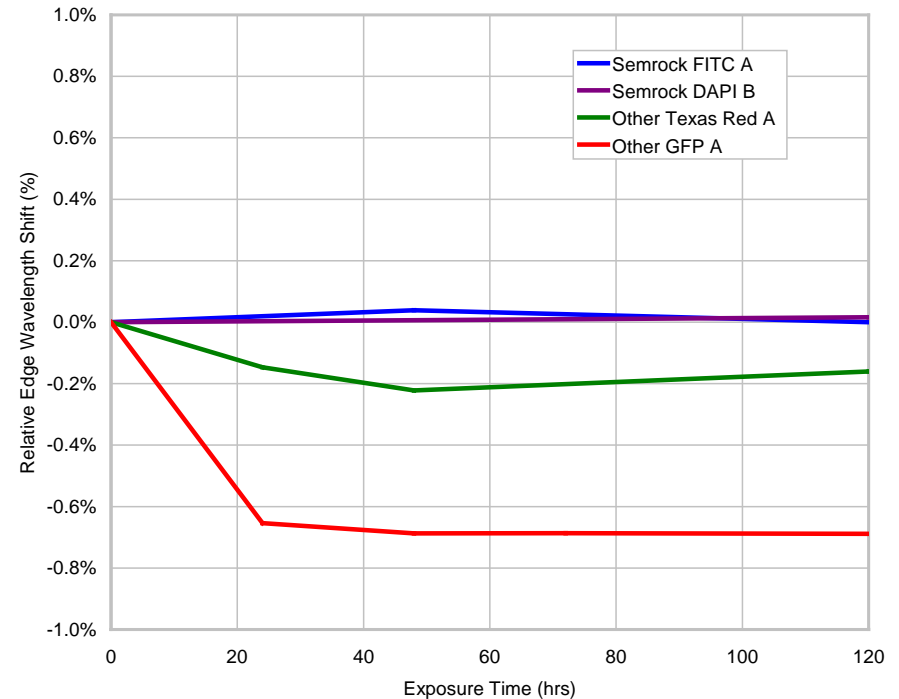

Thank You!